

**UNITED STATES MARINE CORPS**  
School of Infantry  
Training Command  
PSC Box 20161  
Camp Lejeune, NC 28542-0161

MM1307  
10 Mar 04

**STUDENT OUTLINE**

**M224 60MM MORTAR LARGE DEFLECTION AND ELEVATION CHANGE**

**TERMINAL LEARNING OBJECTIVES:**

1. Given a mounted SL-3 complete mortar and a fire command requiring a large deflection and/or elevation change, manipulate the mortar for a large deflection and elevation change by preparing the mortar to fire the mission within 60 seconds. (41TR.03.03)

1. **FIRE COMMANDS**. Fire commands are the technical instructions issued to mortar crews. These instructions enable the gun crews to engage various targets. There are two types of fire commands. They have common factors but different functions.

a. Initial Fire Command. An initial fire command is used to start a fire mission; it contains all the technical information for the gun crew to lay the mortar on the target area. There are eight elements of a fire command, only pertinent information is issued in the fire command.

(1) Mortars to follow. This element has two functions; it alerts the crews to an incoming mission and tells the crews which squads will respond to the commands.

(2) Shell and fuse. This element indicates what ammunition and fuse setting to prepare.

(3) Mortars to fire. This element designates the specific mortar(s) to fire. If the "Mortars to fire" element is the same as the "Mortars to follow" this element is omitted.

(4) Method of fire. In this element, the mortar(s) designated to fire in the preceding element is told how many rounds to fire, how to engage the target, and any special control desired. Also included are the number and type of ammunition to be used in the fire-for-effect phase.

(a) Volley fire. One or more mortars can fire a volley. The command for volley fire is: "\_\_\_ rounds" (the number of rounds).

(b) Interval fire. A volley may also be fired with an interval between each round. The command would be similar to this: "5 ROUNDS \_\_\_ SECOND INTERVAL" (THE TIME BETWEEN ROUNDS).

(c) At my command. This is considered a controlling element. "AT MY COMMAND" is issued when the Platoon Sergeant/Section Leader desires to

control the firing. The response to "AT MY COMMAND" is "at your command". In the absence of a controlling element it is generally understood that the squad may fire when the gun is up.

(d) Manipulation fires (Traversing or Searching). These types of commands are used to cover targets in width and depth. There will be a separate lesson on Manipulation fires.

(5) Deflection. This element gives the exact deflection setting to be placed on the mortar sight. It is always announced in four digits, the first two digits are applied to the course deflection scale and the second two digits are applied to the fine deflection scale. Deflection changes cause the sight telescope to move left or right, and result in the impact of the round moving left or right. The command is always preceded by the word deflection. For example, "DEFLECTION, 3250."

(6) Charge. This element gives the charge consistent with elevation and range as determined from the firing tables. This element indicates to the crew the number of propellant charges to remain on the round.

(7) Time. This element tells the ammunition bearer the exact time setting to set on the fuse. If the Shell and fuse element of the fire command does not call for a fuse, which requires a time setting, this element is omitted. The FDC may issue a fire command that requires the ammunition bearer to set a fuse accurately. For example, " TIME, TWO THREE." (23 SECONDS).

(8) Elevation. This element serves two purposes: first it gives the exact elevation setting that is to be placed on the sight; second it serves as the command to fire. In the absence of a control measure in the "Method of fire" element, the "Mortar to fire" crew may begin firing when their gun is level on the correct sight picture. Elevation is always given in four digits, the first two digits are applied to the course elevation scale and the second two digits are applied to the fine elevation scale. Elevation changes cause the sight to rotate up or down on the elevation mechanism. Elevation in conjunction with charge, cause the impact of the round on the target to fall farther or closer to the mortar position. The rule of thumb is, higher elevation equals shorter range. Elevation is always given in the fire command. And it is always given last.

b. Subsequent Fire Commands. Subsequent fire commands are issued to change firing data or cease firing. Subsequent fire commands only contain data that is changed from the initial fire command, with exception of the elevation, which is always issued in the command. This command should be issued brief and clear, and should contain only the necessary data to accomplish the mission.

## 2. RESTATING OR CORRECTING FIRE COMMANDS

a. If any member of the crew does not understand any element of the fire command he may request that the element be restated by saying "Say again \_\_\_\_\_", followed by the element he didn't understand (deflection, elevation, time). If the command was an initial fire command the misunderstanding is corrected when the restated element is prefaced with "I SAY AGAIN DEFLECTION TWO NINE FOUR ZERO."

(1) In a subsequent fire command any squad member may request clarification in the same fashion as above. The reply would be "THE COMMAND WAS \_\_\_\_\_". (deflection, charge, elevation)

(2) If a subsequent command is issued incorrectly, the Marine issuing the command will correct it by saying "CORRECTION..." followed by the entire subsequent fire command. The term "Correction" cancels the entire command.

(3) To limit errors in transmission all crewmen will echo each element back as it is received.

3. **LARGE DEFLECTION AND ELEVATION CHANGES**. Deflection changes 61 mils or greater are large deflection changes. Elevation changes 101 mils or greater are large elevation changes. The gunner will check to assure he has four fingers of minor adjust and the traverse is centered before beginning the procedure for large deflection and elevation changes.

a. The gunner will be given deflection and elevation change in the form of a fire command causing the gunner to shift the cannon 150-200 mils and an elevation change between 100 and 200 mils.

b. As soon as the gunner hears the deflection he will echo it back then place the new deflection on the sight and look into the sight and move the bipods until the vertical hairline is lined up on the aiming posts. The gunner should attempt to complete crew drill steps one and two before the elevation command is given.

(1) If the gunner moves the bipods and rough levels before he receives the elevation he may skip step three (level elevation) and continue on to step four (level cross level) and five (traverse half the distance to the post and level cross level).

c. When the gunner receives the command "ELEVATION", he will echo the command back then place the new elevation on the sight and look at the elevation vial while manipulating the elevation hand crank until the elevation bubble is level.

(1) If the gunner has not performed step two (rough level) prior to receiving the elevation, he will place the new elevation on the sight and rough level before leveling the elevation.

d. After leveling the elevation bubble, the gunner will level the cross level again, and then check his sight picture.

(1) If the vertical hairline is within 20 mils of the correct sight picture the gunner may traverse half the distance to the correct sight picture and level cross level. This process will be repeated until the correct sight picture is achieved.

(2) If the vertical hairline is not within 20 mils of the correct sight picture the gunner must start the five steps over from step one.

e. When the gunner has checked to assure that both bubbles are level and the vertical hairline is within two mils of the correct sight picture. The gunner will report " GUN #\_\_ UP".

f. The traverse will be within two turns of center when done properly. (This is why you are required to move the bipods if your vertical hairline is more than 20 mils from a correct sight picture.)

4. **SIGHT PICTURES**. There are two types of sight pictures that are acceptable. Both sight pictures are correct and accurate.

a. Aligned sight picture. An aligned sight picture is attained when looking through the sight and the near aiming post covers the far aiming post. This occurs because the line of sight is on or near the original azimuth of lay. This is illustrated in diagram 1.

**DIAGRAM 1 (aligned)**

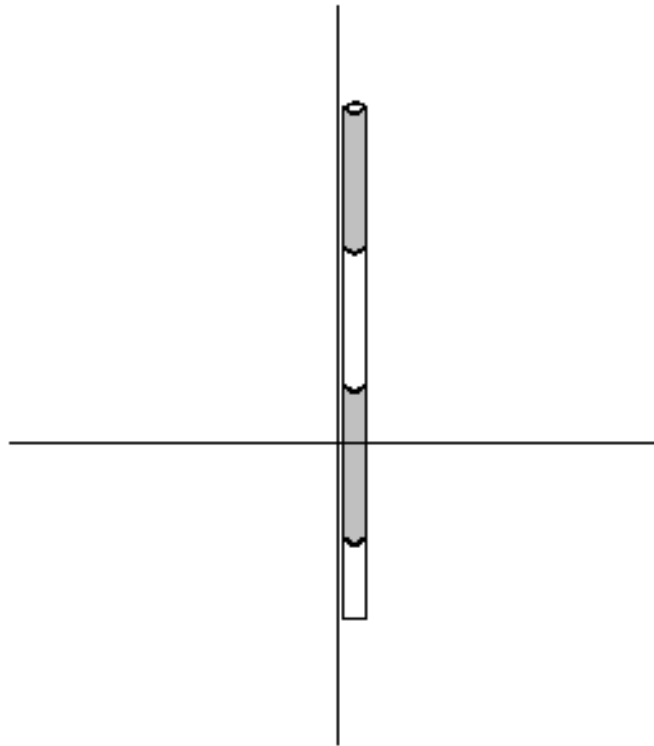

b. Compensated sight picture. A compensated sight picture is attained when looking through the sight and the near aiming post does not align with the far aiming post. This occurs because the line of sight has moved far enough away from the azimuth of lay to change the perspective that you are looking at the posts from. The method for laying in with a compensated sight picture is the same as for an aligned, however the sight picture is different. To correct for the separation between the posts the gunner would use the bottom left edge of the far aiming post as his reference point. If the far post is to the left of the near post, the vertical line is placed on

the left also. The far post is centered between the near post and the vertical line of the reticle pattern.

(1) Compensated right is the sight picture that occurs when the far aiming post is to the right of the near post. The distance between each post and the vertical hairline is equidistant (the same distance between the posts and the line). Compensated right is illustrated in diagram 2.

(2) Compensated left is the sight picture that occurs when the far aiming post is to the left of the near post. The distance between each post and the vertical hairline is equidistant (the same distance between the posts and the line). Compensated left is illustrated in diagram 3.

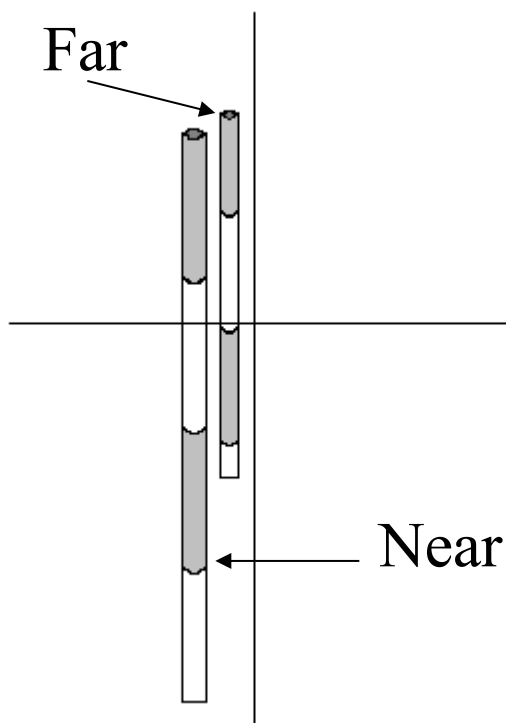

DIAGRAM 2 (COMPENSATED RIGHT)

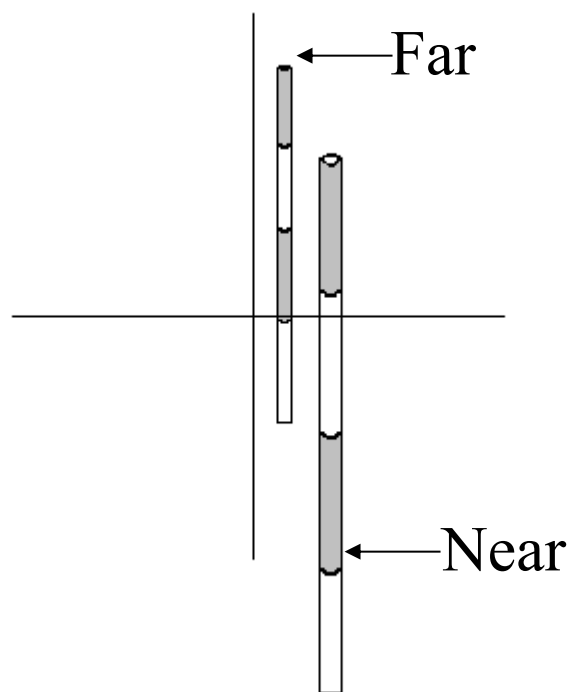

DIAGRAM 3 (COMPENSATED LEFT)

(3) If a compensated sight picture occurs while on the Azimuth of lay (Direction of Fire). The base plate has shifted or the posts were not placed in correctly. This may be corrected by performing refer and realignment of the posts. You will learn how to do this in a later lesson.

**REFERENCES :**

FM 23-90 Mortars, page 3-9 through 3-10.

**EXAM ID:** MM1307P

**EXAM TITLE:** M224 60mm Mortar Large Deflection and Elevation Change Performance Examination

**TLO/ELO:** 41TR.03.03

**STUDENT INSTRUCTIONS:**

1. You are an infantry mortarman and must perform a large deflection and elevation change for a mortar.
2. The squad must perform the small deflection and elevation change within 35 seconds.
3. To achieve mastery, you must perform each of the performance steps correctly and within the allotted time.

**PERFORMANCE STEPS AND/OR PERFORMANCE STANDARDS:**

Performance Steps	Master	Non-Master	Remarks
1. Receive the fire command and echo the fire command.			
2. Place the deflection on the sight.			
3. Place the elevation on the sight.			
4. Move the bipod until the vertical line is on the correct sight picture.			
5. Rough level the mortar.			
6. Level the elevation bubble.			
7. Cross-level the mortar.			
8. Ensure the sight picture is within twenty mils of the correct sight picture. If greater than 20 mils, repeat steps 4 through 8.			
9. If necessary traverse half way to the posts.			
10. Re-level the cross level.			
11. Perform steps 8 and 9 until the vertical hairline is within two mils of the correct sight picture.			
12. Check both bubbles and re-level if necessary.			
13. Announce "Gun up".			